

# *The Boiling Water Reactor*

## **The Boiling Water Reactor**

This material was, for a purpose to be used in a nuclear education, compiled comprehensively with a caution on appropriateness and neutrality of information, based on references of neutral organizations, such as NRC, Wikipedia and ATOMICA, and vendors' information especially on advanced reactors. At the end of this material, references are listed.

## Contents

|  |    |
|--|----|
| <b>Part 1. Descriptions of BWR Power plants</b> .....                        | 1  |
| <b>Chapter 1. BWR Development</b> .....                                      | 1  |
| <b>1.1. General</b> .....  | 1  |
| <b>1.2. BWR Type</b> .....   | 2  |
| <b>Chapter 2. BWR Technologies</b> .....                                     | 5  |
| <b>2.1. Reactor Coolant Recirculation System and Main Steam System</b> ..... | 5  |
| <b>2.2. Structure of BWRs</b> .....  | 5  |
| (1) <b>BWR reactor core and internals</b> .....                              | 5  |
| (2) <b>Nuclear fuel</b> .....  | 6  |
| (3) <b>Control rod and its drive mechanism</b> .....                         | 7  |
| <b>2.3. Engineered Safety Feature</b> .....                                  | 8  |
| (1) <b>Emergency core cooling system</b> .....                               | 8  |
| (2) <b>Reactor containment</b> .....   | 10 |
| <b>2.4. Other Systems and Equipment</b> .....                                | 11 |
| (1) <b>Reactor coolant clean up system</b> .....                             | 11 |
| (2) <b>Reactor core isolation cooling system</b> .....                       | 11 |
| (3) <b>Residual heat removal system</b> .....                                | 11 |
| (4) <b>Waste processing system</b> .....                                     | 11 |
| (5) <b>Fuel handling equipment</b> .....                                     | 12 |
| (6) <b>Fuel pool cooling and cleanup system</b> .....                        | 12 |
| (7) <b>Turbine-generator equipment</b> .....                                 | 12 |
| <b>2.5. Power Control of BWR</b> .....                                       | 12 |
| (1) <b>Power control method and self-regulating characteristics</b> .....    | 12 |
| (2) <b>Heat transfer and power control</b> .....                             | 13 |
| (3) <b>Load fluctuation and reactor pressure reduction</b> .....             | 13 |
| <b>Chapter 3. Features of BWR</b> .....                                      | 13 |
| <b>3.1. BWR Design</b> .....   | 13 |
| (1) <b>Generation of steam in a reactor core</b> .....                       | 13 |
| (2) <b>Feed water system</b> .....   | 14 |
| (3) <b>Fluid recirculation in the reactor vessel</b> .....                   | 14 |
| (4) <b>Reactor power control system</b> .....                                | 14 |
| (5) <b>Steam turbines</b> .....  | 15 |
| (6) <b>Size of reactor core</b> .....  | 15 |
| <b>Part 2. Advanced BWRs</b> .....   | 16 |
| <b>Chapter 4. ABWR Development</b> .....                                     | 16 |
| <b>Chapter 5. ABWR Technologies</b> .....                                    | 18 |

|   |    |
|---|----|
| <b>5.1 Features of ABWR</b> .....   | 18 |
| <b>(1) Reactor pressure vessel and internals</b> .....                    | 18 |
| <b>(2) External recirculation system eliminated</b> .....                 | 21 |
| <b>(3) Internal pump</b> .....  | 21 |
| <b>(4) Control rod and drive mechanism</b> .....                          | 23 |
| <b>(5) Safety - Simplified active safety systems</b> .....                | 24 |
| <b>(6) Digital control and instrumentation systems</b> .....              | 26 |
| <b>(7) Control room design</b> .....                                      | 27 |
| <b>(8) Plant construction</b> .....                                       | 27 |
| <b>Chapter 6. Economic Simplified Boiling Water Reactor (ESBWR)</b> ..... | 28 |
| <b>6.1 ESBWR and Natural Recirculation</b> .....                          | 28 |
| <b>6.2 ESBWR Passive Safety Design</b> .....                              | 32 |
| <b>Chapter 7. Current status</b> .....                                    | 35 |

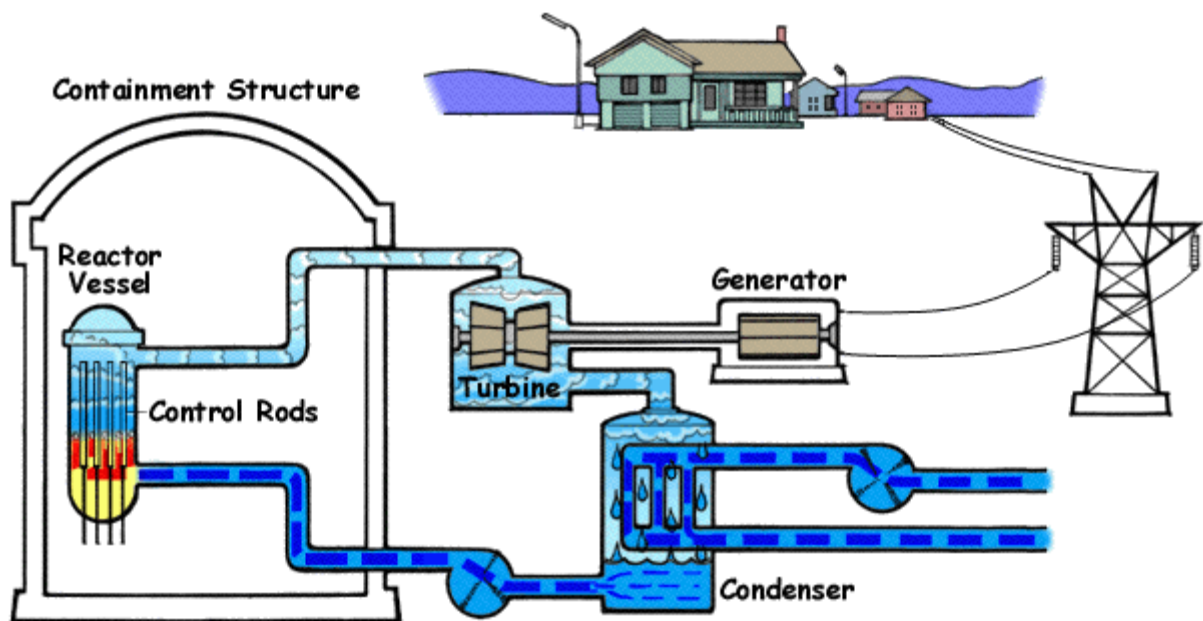
## Part 1. Descriptions of BWR Power plants

### Chapter 1. BWR Development

#### 1.1. General

Boiling water reactors (BWRs) are nuclear power reactors utilizing light water as the reactor coolant and moderator to generate electricity by directly boiling the light water in a reactor core to make steam that is delivered to a turbine generator. There are two operating BWR types, roughly speaking, i.e., BWRs and ABWRs (advanced boiling water reactors)

The outline of a BWR power plant is shown in Figure 1.



**Figure 1. Outline of BWR Power Plant**

#### [More details on the System Outline of ABWR Power Plant](#)

A pressurized water reactor (PWR) was the first type of light-water reactor developed because of its application to submarine propulsion. The civilian motivation for the BWR is reducing costs for commercial applications through design simplification and lower pressure components.

In contrast to the pressurized water reactors that utilize a primary and secondary loop, in civilian BWRs the steam going to the turbine that powers the electrical generator is produced in the reactor core rather than in steam generators or heat exchangers. There is just a single circuit in a civilian BWR in which the water is at lower pressure (about 75 times atmospheric pressure) so that it boils in the core at about 285°C.

BWRs have been originally developed by GE. GE started its development in 1950s as light water reactor type nuclear power reactors, and the Dresden Unit-1 (200,000 kWe) commissioned in July 1960 is the first BWR nuclear power station. After that, the GE company has supplied many BWRs, Siemens (KWU, Germany), ABB-Atom (Switzerland/Sweden) and Toshiba and Hitachi (Japan) also supplied many BWRs. In the following, features and types of BWRs, mainly of conventional BWRs, are explained and those of ABWRs are addressed in the next.

For BWRs, the steam void due to reactor coolant boiling has a negative reactivity effect, which can suppress a power rise even if a positive reactivity is added. The reactor power can be controlled by two methods: reactor-coolant recirculation-flow control and control rod operation.

A BWR nuclear power plant consists of the reactor coolant recirculation system and main steam system that compose a nuclear reactor, engineered safety features that consist of the emergency core cooling system, reactor core isolation cooling system, containment cooling system and boric-acid injection system, turbine and generator equipment and other systems, such as the reactor coolant purification system, waste processing equipment, fuel handling equipment, other auxiliary equipment, etc.

## 1.2. BWR Type

Major reactor core parameters of BWR-2 to BWR-4, which are in operation in Japan are shown in Table 1.

**Table 1 Main Parameters for BWR Core**

| No. | Item                      | Tsuruga Unit-1 (BWR-2) | Fukushima Unit-1 (BWR-3) | Hamaoka Unit-2 (BWR-4) | Tokai Unit-2 (BWR-5) | Kashiwazaki Unit-6 (ABWR) |
|-----|---------------------------|------------------------|--------------------------|------------------------|----------------------|---------------------------|
| (1) | Thermal output (MW)       | 1064                   | 1380                     | 2436                   | 3293                 | 3926                      |
| (2) | Electric output (MW)      | 357                    | 460                      | 840                    | 1100                 | 1356                      |
| (3) | Core equivalent dia. (m)  | 3.02                   | 3.44                     | 4.07                   | 4.75                 | 5.16                      |
| (4) | Core effective height (m) | 3.66                   | 3.66                     | 3.71                   | 3.71                 | 3.71                      |
| (5) | Fuel assemblies (Number)  | 308                    | 400                      | 560                    | 764                  | 872                       |
| (6) | Control rod (Number)      | 73                     | 97                       | 137                    | 185                  | 205                       |
| (7) | Power density (kw/l)      | About 40               | About 40                 | About 50               | About 50             | About 50                  |

Improvement and history of BWR fuel in Japan are shown in Table 2. In 1960s, the development started including introduction of overseas technologies under license agreements, and the fuel type has been changed from 6x6 to 9x9 adopting many improvements resulting from nuclear and mechanical research and developments.

**Table 2 BWR Fuel Improvement in Japan**

| Year/Item | Objective                           | Major Improvement   | Fuel Type       | Reactor Type                    |
|-----------|-------------------------------------|---|-----------------|---------------------------------|
| 1960      | Development in general              | Basic study on fuel material<br>Fuel rod irradiation test<br>Core design study<br>Fuel manufacturing technologies | 6x6             | JPDR (BWR-1)                    |
| 1970      | Initial performance development     | 6x6 type fuel demonstration<br>Domestic fuel performance demonstration  | 7x7             | Tsuruga-1 (BWR-2)               |
|           |                                     | 7x7 type fuel development (high power density and long fuel rod development)                                      | 7x7R            |                                 |
| 1980      | Reliability improvement             | Reliability improvement<br>Improved 7x7 type fuel development   | 8x8             | Fukushima I-1 (BWR-3)           |
|           |                                     | Preconditioning fuel operation<br>8x8 type fuel development   | 8x8 R           | Fukushima I-2 (BWR-4)           |
| 1990      | Availability improvement            | Re-evaluation of preconditioning fuel operation<br>He pressurized fuel  | Liner 8x8 R     | Tokai-2 (BWR-5)                 |
|           |                                     | Two regional fuel reactivity design<br>Controlled cell core   | High Burnup 8x8 | Fukushima II-2 (Improved BWR-5) |
| 2000      | High performance / high burnup fuel | Zirconium liner fuel<br>High burnup fuel  |                 | Kashiwazaki-6 (ABWR)            |

Improvement of BWR containment is shown in Figure 2. Five types of containments were applied for Japanese BWRs. Typical design for each type of containment is illustrated with major dimensions. The design has attained significant improvement in the total volume per output, resulting in a large cost benefit.

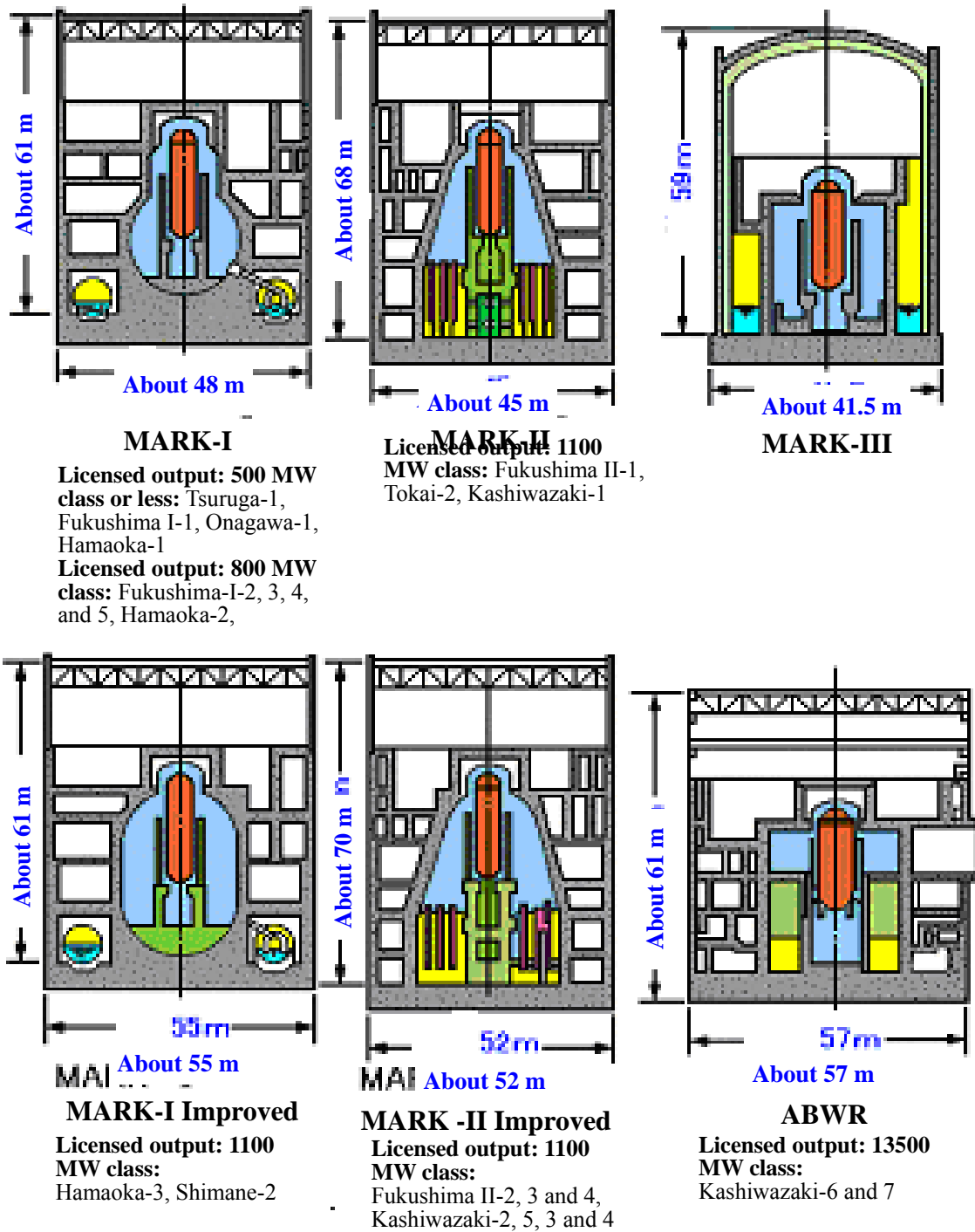


Figure 2. History of BWR Containment

There are two operating BWR types, roughly speaking, i.e. BWRs including their modifications and ABWRs (advanced BWRs). The first commercial power reactor constructed in U.S. was the Dresden Unit-1 (full power operation in July 1960), which was the BWR-1 reactor. This BWR-1 reactor was dual cycle like a pressurized water reactor and adopted a dry type reactor containment vessel. The BWR-2 and the subsequent ones were designed to increase the power density that results in a smaller core size, to simplify the system adopting a direct cycle with a steam drum provided inside a reactor vessel, to multiplex the emergency core cooling system (ECCS), and to reduce the containment vessel volume adopting a pressure-suppression-type pool, which led to the current operating BWR designs.

## Chapter 2. BWR Technologies

### 2.1. Reactor Coolant Recirculation System and Main Steam System

Boiling water reactors (BWRs) are nuclear power reactors generating electricity by directly boiling the light water in a reactor pressure vessel to make steam that is delivered to a turbine generator. After driving a turbine, the steam is converted into water with a condenser (cooled by sea water in Japan), and pumped into the reactor vessel with feedwater pumps. A part of the water is sent into the reactor vessel after being pressurized with recirculation pumps installed outside of the vessel and fed into the reactor core from the bottom part of the reactor vessel with jet pumps.

Inside of a BWR reactor pressure vessel (RPV), feedwater enters through nozzles high on the vessel, well above the top of the nuclear fuel assemblies (these nuclear fuel assemblies constitute the "core") but below the water level. The feedwater is pumped into the RPV from the condensers located underneath the low pressure turbines and after going through feedwater heaters that raise its temperature using extraction steam from various turbine stages.

The feedwater enters into the downcomer region and combines with water exiting the water separators. The feedwater subcools the saturated water from the steam separators. This water now flows down the downcomer region, which is separated from the core by a tall shroud. The water then goes through either jet pumps or reactor internal pumps that provide additional pumping power (hydraulic head). The water now makes a 180 degree turn and moves up through the lower core plate into the nuclear core where the fuel elements heat the water. When the flow moves out of the core through the upper core plate, about 12–15% of the volume of the flow is saturated steam.

### 2.2. Structure of BWRs

#### (1) BWR reactor core and internals

Reactor core and internal structures of 1,100MWe class BWR reactor vessel are shown in Figure 3. In a reactor vessel, there are a reactor core that mainly consists of fuel assemblies and control rods in the center, equipment for generating steam for a turbine, such as a steam-water separator and a steam dryer in the upper part of the vessel, equipment for



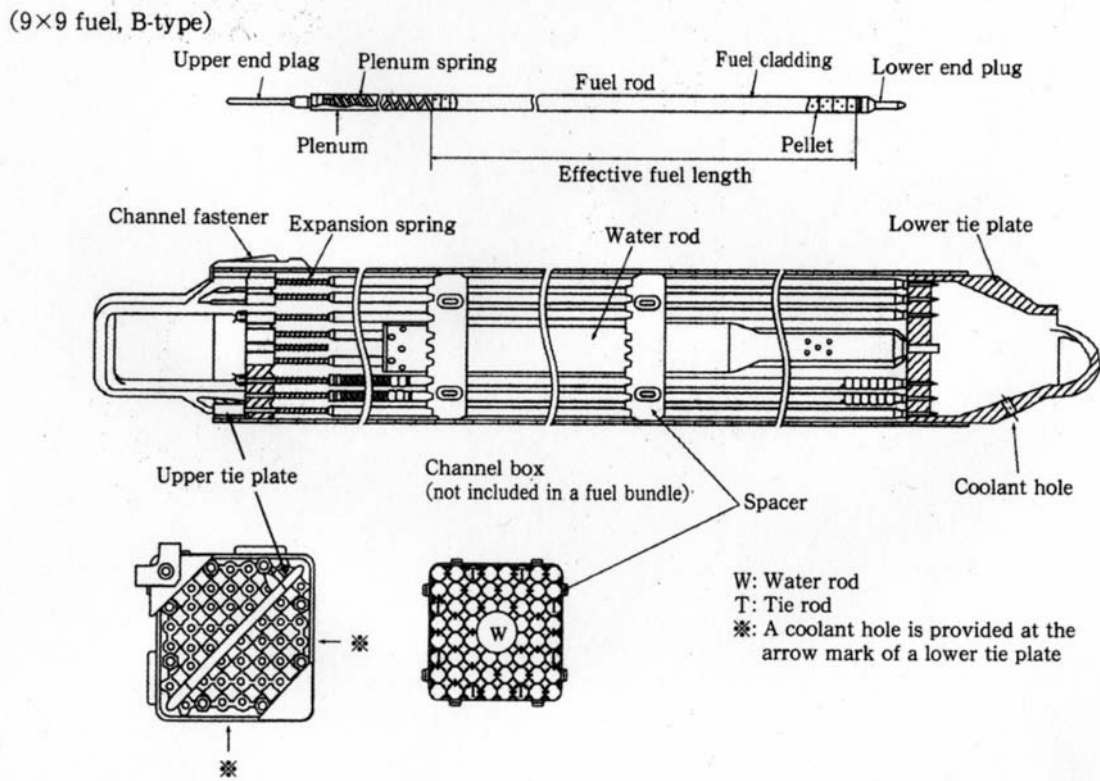
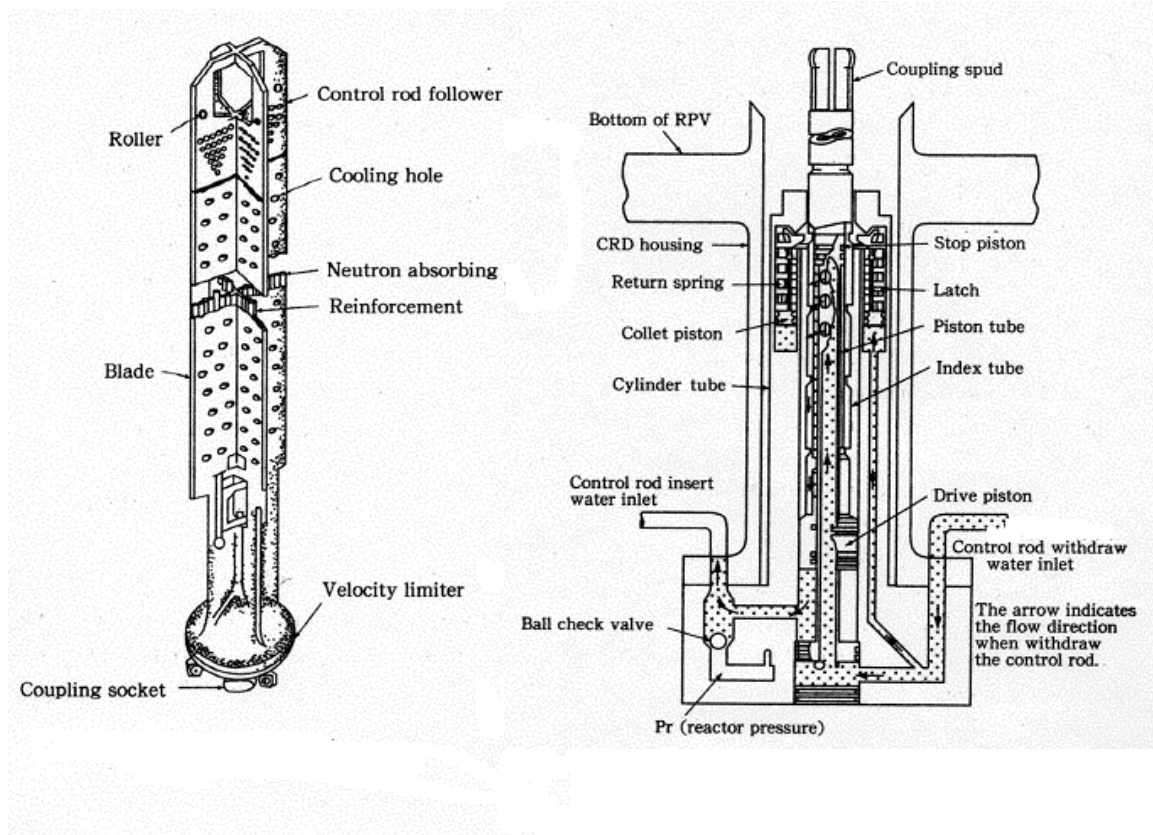


Figure 4. BWR Nuclear Fuel Structure

### (3) Control rod and its drive mechanism

BWR control rods are composed of blades in a shape of cruciform in order to move through the gaps formed between four channels of fuel assemblies as shown in Figure 5. Types of control rods are, in terms of the absorber materials, boron carbide ( $B_4C$ ), hafnium (Hf) and combination of these. A velocity limiter of an umbrella shape is provided at the lower portion of the control rod to slow down the dropping velocity in case of a control rod drop accident. Moreover, a connector to couple a control rod to a control rod drive mechanism is provided.



**Figure 5. BWR Control Rod and its Drive Mechanism**

There are two types of the control rod drive mechanism: hydraulic pressure drive and motor drive. Both types utilize the nitrogen-gas pressure stored in accumulators as driving power for fast insertion of control rods. When an anomaly occurs or could occur at a nuclear reactor, the fast insertion of all control rods into a reactor core is carried out all at once from the lower part of reactor core to shutdown nuclear reactor operation (it is called that a nuclear reactor is scrammed.) The boric acid solution injection system is provided to inject a neutron absorber material into the reactor core to stop reactor operation when the control rods cannot be inserted and the nuclear reactor cannot be placed in low-temperature shutdown mode.

## 2.3. Engineered Safety Feature

### (1) Emergency core cooling system

At an abnormal event of a BWR, actuation of the reactor shutdown system (a part of the safety protection system) stops the nuclear reactor operation securely. The emergency core cooling system (ECCS) is provided for the case when a break accident occurs to reactor coolant system piping etc. and the reactor coolant is lost from a reactor core (loss of coolant accident, LOCA). This system consists of one high pressure core cooling system, one low pressure core cooling system, and three low pressure core injection (reflooder) systems.

[More Details on Safety Design](#)

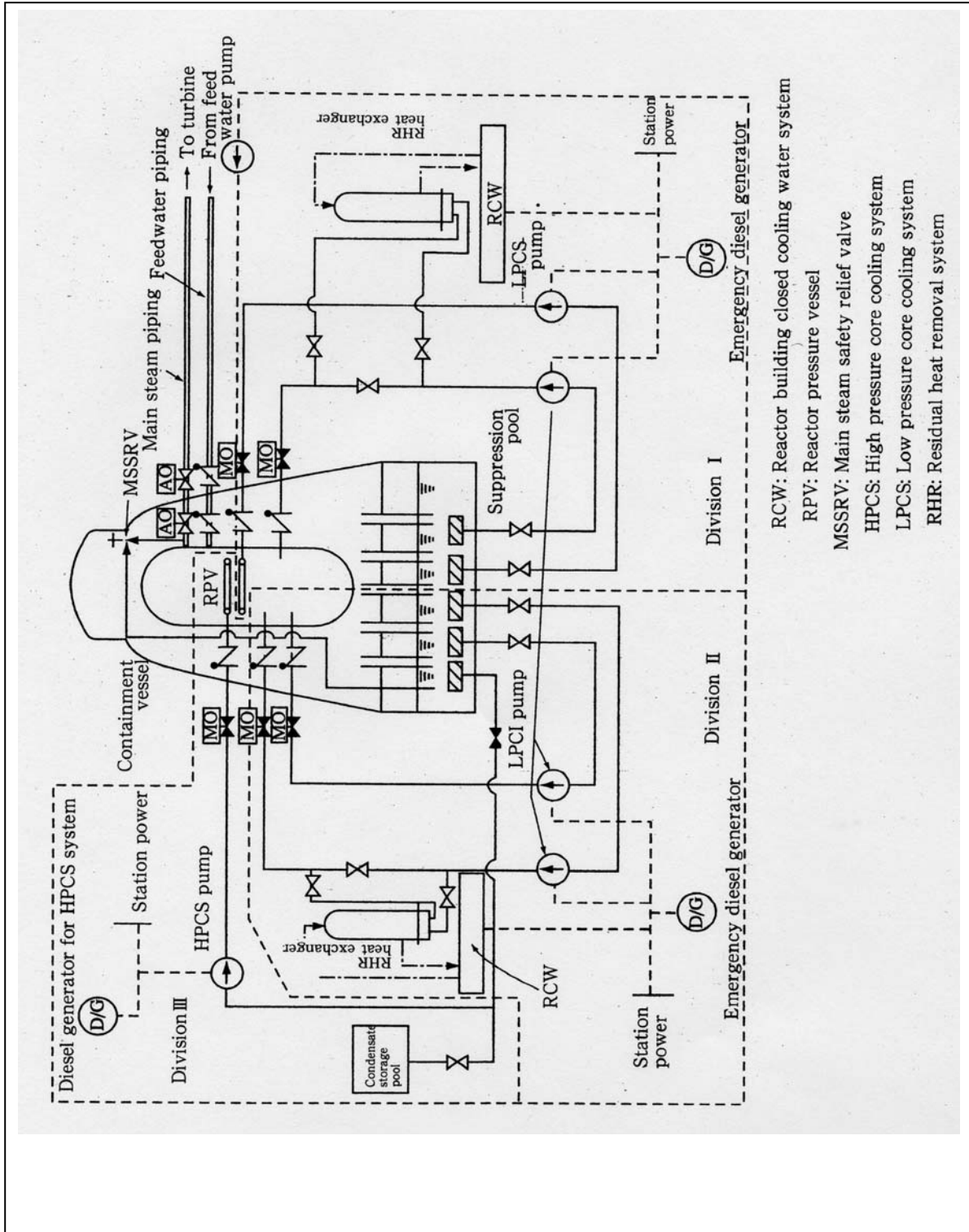
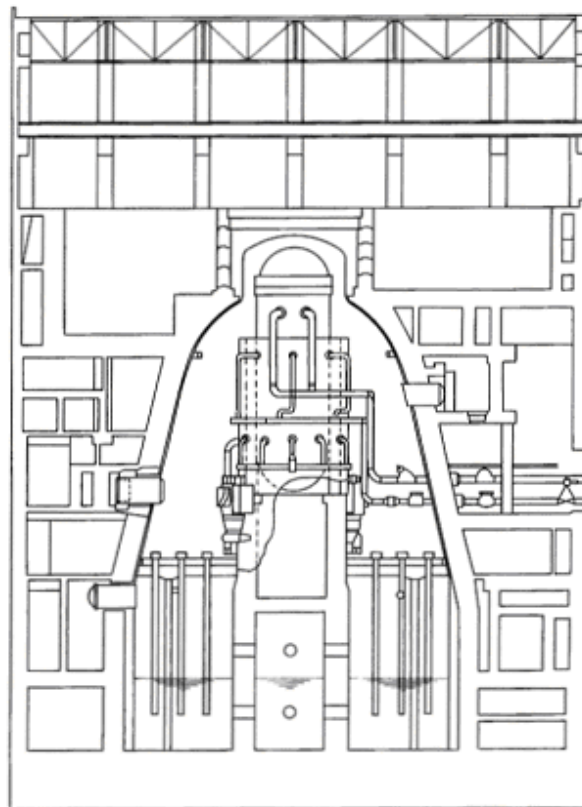


Figure 6. ECCS Network for BWR-5, 1100MWe

## (2) Reactor containment

Radioactive materials are released into the high temperature and high pressure coolant when a fuel failure occurs. Therefore, a reactor containment is provided so that the coolant would not discharge to the outside (Figure 7). All BWR containments are pressure suppression (pressure suppression pool) type, and the steam discharged into the containment is led to the water pool of the pressure suppression chamber, cooled and condensed, and the pressure rise within the containment is suppressed as a result. Moreover, as the temperature and pressure of the containment rise due to the fuel decay heat in a long term after an accident, it is necessary to cool the inside of the containment. Furthermore, it is also necessary to remove radioactive materials such as iodine within the containment. For such purposes, the containment spray system is provided within the containment (drywell spray, pressure suppression chamber spray). Furthermore, the standby gas treatment system is provided in the reactor building so that the radioactive materials will not be released to the outside of the containment.



**Figure 7. BWR Containment in the Reactor Building (Improved Mark-II)**

In addition, following a loss of coolant accident, the temperature of fuel cladding could rise and hydrogen could be generated by a water-metal reaction, which could impair the containment integrity due to hydrogen gas combustion. In order to prevent such a case, BWR containments are kept inert with nitrogen gas (Mark-III type containment is designed not to use the nitrogen gas, but it is not adopted in Japan) during normal operation, and the

flammability control system to prevent hydrogen combustion by recombining the generated hydrogen gas with oxygen gas.

## 2.4. Other Systems and Equipment

### (1) Reactor coolant clean up system

The reactor coolant clean up system is provided to keep the coolant purity high, and consists of pumps, regenerative heat exchangers, non-regenerative heat exchangers, filter demineralizers, auxiliary equipment, etc.

The reactor coolant clean up system, together with the condensate cleanup system, keeps the coolant properties within the following values;

|                                      |   |                      |
|--------------------------------------|---|----------------------|
| Electric conductivity (25 degrees C) | 1 | micro-S / cm or less |
| Cr                                   |   | 0.1 ppm or less      |
| pH (25 degrees C)                    |   | 5.6 - 8.6            |

### (2) Reactor core isolation cooling system

The reactor core isolation cooling system is provided to inject the condensed water of residual heat removal system or condensate storage tank water, etc. into a reactor core with the turbine-driven pump using a part of the nuclear reactor steam to maintain the reactor water level, when supply of the condensate or feed water is stopped due to a certain cause after the reactor shutdown.

### (3) Residual heat removal system

The residual heat removal system is provided for removal of the residual heat during a normal reactor shutdown and nuclear reactor isolation condition and for core cooling in case of a loss of coolant accident, etc.

The system consists of three independent loops, consisting of two sets of heat exchangers and three sets of pumps, which can be used in four modes by changing valve lineup. In addition, the system can cool the fuel pool using a connection line to the fuel pool cooling and cleanup system, when required.

### (4) Waste processing system

Wastes generated in a plant are divided into gas, liquid and solid materials, and are processed separately. The gaseous waste, after attenuating the radioactivity to sufficiently low level with an activated-carbon-type noble gas hold-up device, is discharged from a vent stack monitoring the concentrations of radioactive materials. The liquid waste, after being collected from each generating source, is processed with a filter, a demineralizer and a waste evaporator, and is reused as make-up water or discharged. The liquid waste condensed with the waste evaporator is processed as a solid waste. The solid waste is processed by solidification, incineration, compression etc. corresponding to the type and canned in a drum for storage in a storage facility. In the solidification method, there are bituminization, plastic solidification and cement solidification.

### **(5) Fuel handling equipment**

Refueling is carried out once per 12 to 24 months in principle for an equilibrium cycle, and the required refueling time period is about 20 days. The number of removed fuel assemblies at one refueling is 20 to 30% of the total fuel assemblies in a core.

### **(6) Fuel pool cooling and cleanup system**

The fuel pool cooling and cleanup system is provided to remove the decay heat of the spent fuel with the heat exchangers of the reactor building closed cooling water system to cool the fuel pool water, and to maintain the water purity and visibility of the fuel pool, reactor well and pit for the steam dryer and steam-water separator by filter-demineralization of the fuel pool water with a filter demineralizer,

The fuel pool cooling and cleanup system consists of pumps, filter demineralizers, heat exchangers, auxiliary equipment etc.

### **(7) Turbine-generator equipment**

#### **(a) Steam turbine**

Generally speaking, the steam turbine for nuclear power consumes more steam per unit output and is a larger size compared with the turbine for thermal power plants, as the turbine inlet steam condition is not good compared with that for thermal power plants.

Therefore, the rotation frequency of both the high-pressure and low pressure turbines is 1,500 to 1,800 rpm.

#### **(b) Generator**

The turbine generator for nuclear power plants has no essential difference from that for thermal power plants.

## **2.5. Power Control of BWR**

### **(1) Power control method and self-regulating characteristics**

The BWR generates steam with pressure about  $70 \text{ kg/cm}^2$  by boiling light water in the reactor core. Moreover, the amount of steam bubbles (void) generated by the boiling is controlled with recirculation pumps (variable velocity pump) to control the nuclear reaction (power), which is called the recirculation flow control system. As control rods are withdrawn out of the core, the reactivity increases and then, the power (heat generation) increases, which results in increase of steam void leading to reduction of moderator density, and the rate of uranium fission becomes small and the reactivity decreases, which balances and stabilizes the reactor power (reactivity). As control rods are inserted into the core, the reactivity decreases and the power decreases, which results in decrease of steam void leading to increase of moderator density, and the rate of uranium fission becomes large and the reactivity increases, which balances and stabilizes the reactor power. In this way, BWRs have a self-regulating characteristic of the reactor power.

## **(2) Heat transfer and power control**

The heat generated in fuel rods is transferred to the reactor coolant. The magnitude of heat transferred according to the temperature difference between the heat transfer surface and the coolant has been obtained in many experiments. Since the heat transfer decreases in the transition film-boiling region in which the boiling becomes violent that could cause a burnout of fuel cladding tube, the heat transfer in the nucleate-boiling region is utilized in BWR. Therefore, the reactor operation limits are imposed on BWRs not to approach to the transition film-boiling region during normal operation and abnormal operational transients.

## **(3) Load fluctuation and reactor pressure reduction**

When BWRs experience a load fluctuation in automatic power control mode, first of all, the reactor power is adjusted by increase or decrease of the recirculation flow. Automatic power control is adjusted during about 70%--100% of the rated power. If electrical grid demands increase turbine generator output power, at first the power control system increases the recirculation flow that results in increase of the reactor power. The reactor pressure is controlled to be constant by opening of a turbine control valve by reactor pressure system. Opening of a turbine control valve increases the steam flow and the turbine generator output power. This method is called "the reactor master / turbine slave (nuclear reactor priority method)." In addition, when an abnormal turbine trip occurs, the steam flow is interrupted and the reactor scram occurs to protect abnormal pressure rise. Also, bypass valves are opened to bypass the steam to main condenser.

## **Chapter 3. Features of BWR**

The BWR is characterized by two-phase fluid flow (water and steam) in the upper part of the reactor core. Light water (i.e., common distilled water) is the working fluid used to conduct heat away from the nuclear fuel. The water around the fuel elements also "thermalizes" neutrons, i.e., reduces their kinetic energy, which is necessary to improve the probability of fission of fissile fuel. Fissile fuel material, such as the U-235 and Pu-239 isotopes, have large capture cross sections for thermal neutrons.

### **3.1. BWR Design**

#### **(1) Generation of steam in a reactor core**

In contrast to the pressurized water reactors that utilize a primary and secondary loop, in civilian BWRs the steam going to the turbine that powers the electrical generator is produced in the reactor core rather than in steam generators or heat exchangers. There is just a single circuit in a civilian BWR in which the water is at lower pressure (about 75 times atmospheric pressure) compared to a PWR so that it boils in the core at about 285°C. The reactor is designed to operate with steam comprising 12 to 15% of the volume of the two-phase coolant flow (the "void fraction") in the top part of the core, resulting in less moderation, lower neutron efficiency and lower power density than in the bottom part of the core. In comparison, there is no significant boiling allowed in a PWR because of the high pressure maintained in its primary loop (about 158 times atmospheric pressure).

## (2) Feed water system

Inside of a BWR reactor pressure vessel (RPV), feedwater enters through nozzles high on the vessel, well above the top of the nuclear fuel assemblies (these nuclear fuel assemblies constitute the "core") but below the water level. The feedwater is pumped into the RPV from the condensers located underneath the low pressure turbines and after going through feedwater heaters that raise its temperature using extraction steam from various turbine stages.

## (3) Fluid recirculation in the reactor vessel

The heating from the core creates a thermal head that assists the recirculation pumps in recirculating the water inside of the RPV. A BWR can be designed with no recirculation pumps and rely entirely on the thermal head to recirculate the water inside of the RPV. The forced recirculation head from the recirculation pumps is very useful in controlling power, however. The thermal power level is easily varied by simply increasing or decreasing the speed of the recirculation pumps.

The two phase fluid (water and steam) above the core enters the riser area, which is the upper region contained inside of the shroud. The height of this region may be increased to increase the thermal natural recirculation pumping head. At the top of the riser area is the water separator. By swirling the two phase flow in cyclone separators, the steam is separated and rises upwards towards the steam dryer while the water remains behind and flows horizontally out into the downcomer region. In the downcomer region, it combines with the feedwater flow and the cycle repeats.

The saturated steam that rises above the separator is dried by a chevron dryer structure. The steam then exits the RPV through four main steam lines and goes to the turbine.

## (4) Reactor power control system

Reactor power is controlled via two methods: by inserting or withdrawing control rods and by changing the water flow through the reactor core.

Positioning (withdrawing or inserting) control rods is the normal method for controlling power when starting up a BWR. As control rods are withdrawn, neutron absorption decreases in the control material and increases in the fuel, so reactor power increases. As control rods are inserted, neutron absorption increases in the control material and decreases in the fuel, so reactor power decreases. Some early BWRs and the proposed ESBWR designs use only natural circulation with control rod positioning to control power from zero to 100% because they do not have reactor recirculation systems.

Changing (increasing or decreasing) the flow of water through the core is the normal and convenient method for controlling power. When operating on the so-called "100% rod line," power may be varied from approximately 70% to 100% of rated power by changing the reactor recirculation flow by varying the speed of the recirculation pumps. As flow of water through the core is increased, steam bubbles ("voids") are more quickly removed from the core, the amount of liquid water in the core increases, neutron moderation increases, more neutrons are slowed down to be absorbed by the fuel, and reactor power increases. As flow of

water through the core is decreased, steam voids remain longer in the core, the amount of liquid water in the core decreases, neutron moderation decreases, fewer neutrons are slowed down to be absorbed by the fuel, and reactor power decreases.

### **(5) Steam turbines**

Steam produced in the reactor core passes through steam separators and dryer plates above the core and then directly to the turbine, which is part of the reactor circuit. Because the water around the core of a reactor is always contaminated with traces of radionuclides, the turbine must be shielded during normal operation, and radiological protection must be provided during maintenance. Most of the radioactivity in the water is very short-lived (mostly N-16, with a 7 second half life), so the turbine hall can be entered soon after the reactor is shut down.

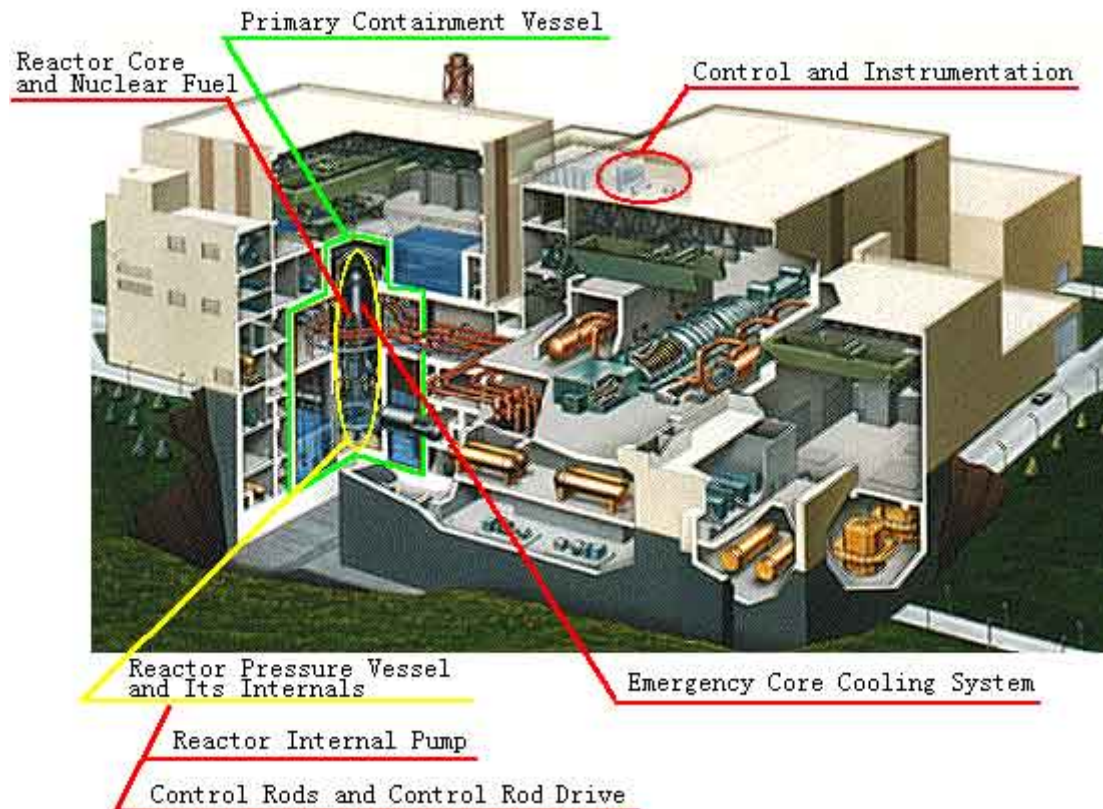
### **(6) Size of reactor core**

A modern BWR fuel assembly comprises 74 to 100 fuel rods, and there are up to approximately 800 assemblies in a reactor core, holding up to approximately 140 tonnes of uranium. The number of fuel assemblies in a specific reactor is based on considerations of desired reactor power output, reactor core size and reactor power density.

## Part 2. Advanced BWRs

### Chapter 4. ABWR Development

ABWRs are Generation III reactors based on the boiling water reactor. The ABWR was designed by General Electric and Japanese BWR suppliers. The standard ABWR plant design has a net output of about 1350 megawatts electrical.



**Figure 8. ABWR Power Plant Structure**

Major differences between the BWR and ABWR designs are as shown in Table 3: the reactor coolant pump is changed from the combination of recirculation pumps and jet pumps to internal pumps (in-reactor-vessel type pump), the control rod drive system is changed to a combination of a motor-driven drive and a hydraulic pressure drive from the hydraulic pressure drive, and the containment is a reinforced-concrete type containment vessel. In addition, the kashiwazaki kariwa Unit-6 and Unit-7 (electrical output is 1,356,000kW gross, respectively) in Japan have started commercial operation as the first operating ABWRs in the world.

**Table 3. Major Specifications for BWR and ABWR**

| Items                                  | ABWR   | Conventional BWR                                  |
|--|--|---|
| Electricity output MWe                 | 1350 class   | 1100 class  |
| Thermal output MWt                     | 3926   | 3293  |
| Reactor pressure kgf/cm <sup>2</sup> g | 72.1   | 70.7  |
| Feed water temperature Degree-C        | 215  | 215   |
| Core flow Kg/h                         | About 52x10 <sup>6</sup>                           | About 48x10 <sup>6</sup>                          |
| Fuel type                              | New-type 8x8                                       | New-type 8x8                                      |
| Number of fuel assemblies              | 872  | 764   |
| Number of control rods                 | 205  | 185   |
| Reactor pressure vessel I D: m<br>H: m | About 7.1<br>About 21                              | About 6.4<br>About 22                             |
| Reactor water recirculation system     | Reactor internal pumps (10)                        | Outer recirculation pumps (2) + jet pumps (20)    |
| Control rod drive mechanism            |  |   |
| Power control                          | Fine motion CR drive (FMCRD) system                | Hydraulic pressure CR drive (CRD) system          |
| Scram                                  | Fast scram with hydraulic pressure drive           | Fast scram with hydraulic pressure drive          |
| Steam flow restrictor                  | Reactor pressure vessel nozzle                     | Main steam pipe Venturi nozzle                    |
| Emergency core cooling system          | Low pressure reflooder system (3 systems)          | Low pressure reflooder system (3 systems)         |
|  | High pressure core reflooder system (2 systems)    | Low pressure core spray system                    |
|  | Reactor core isolation cooling system              | High pressure core spray system                   |
|  | Automatic depressurization system                  | Automatic depressurization system                 |
| Residual heat removal system           | 3 systems (common use)                             | 2 systems (common use)                            |
| Containment                            | Building integral-type made of reinforced concrete | Advanced Mark-I or advanced Mark-II made of steel |
| Main turbine                           |  |   |
| Type                                   | TC8F52''   | TC8F41''/43''                                     |
| Thermal cycle                          | 2 stage reheating                                  | Non-reheating                                     |
| Number of steam extraction stages      | 6  | 6   |

[More details in Standard ABWR Technical Data](#)

Following the Kashiwazaki-Kariwas Unit-6 and Unit-7, the Ham aoka Unit-5 of the Chubu Electric Power Co., Inc., which is the second generation ABWR adopting new technologies, started its commercial operation in January 2005 as the world's largest class output power station.

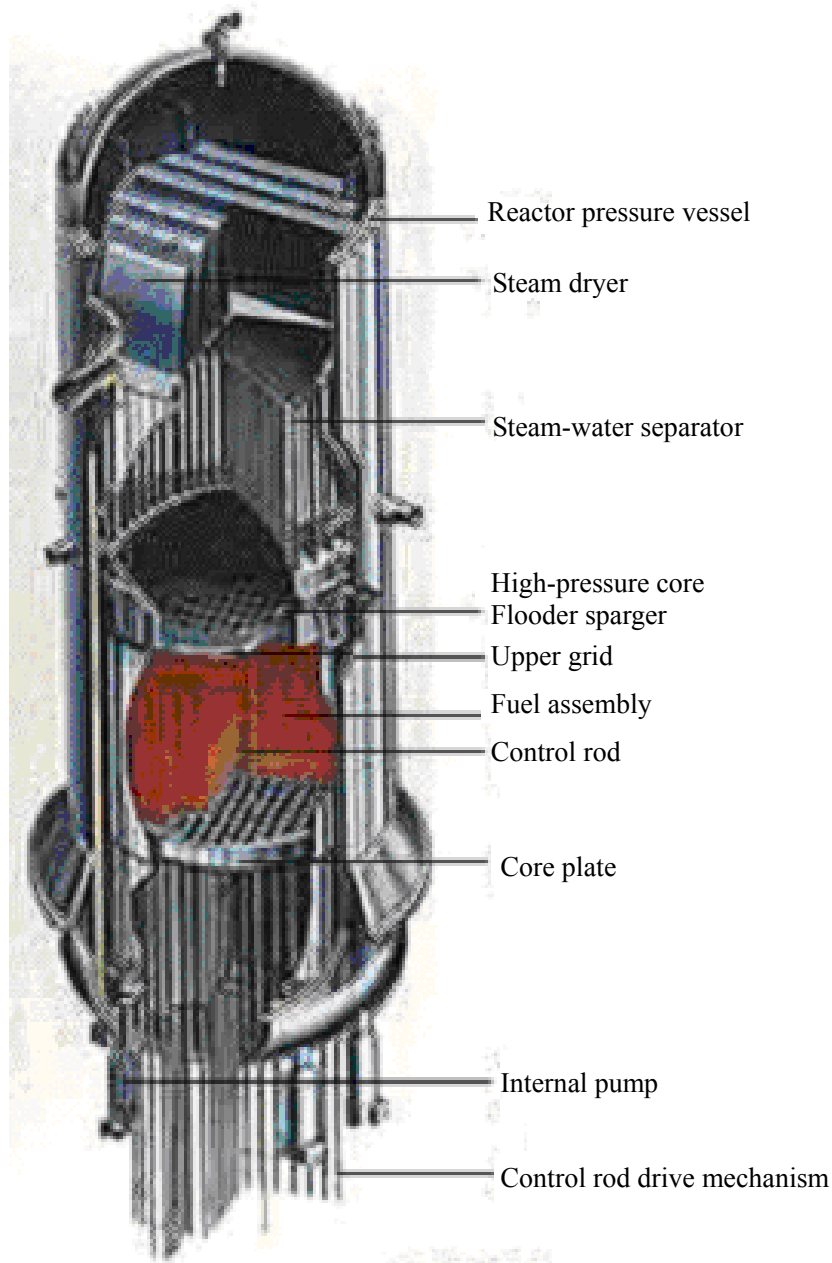
## **Chapter 5. ABWR Technologies**

### **5.1 Features of ABWR**

ABWR characterized by the simplified direct cycle type is completed as a high reliability and safety nuclear reactor with many improvements, such as optimization of the core power density and fuel burnup, adoption of a built-in steam-water separator, multiple emergency core cooling system, etc. In addition to those improvements, ABWRs adopt the following superior technologies.

#### **(1) Reactor pressure vessel and internals**

The nuclear reactor of advanced boiling water reactor (ABWR) adopts the internal-pump system as a reactor-coolant recirculation system, which installs pumps in a reactor pressure vessel. The reactor internals consist of internal structures, such as steam-water separator and steam dryer, and a core support for fuel assemblies as shown in Figure 9.



**Figure 9. Reactor Pressure Vessel and Internals**

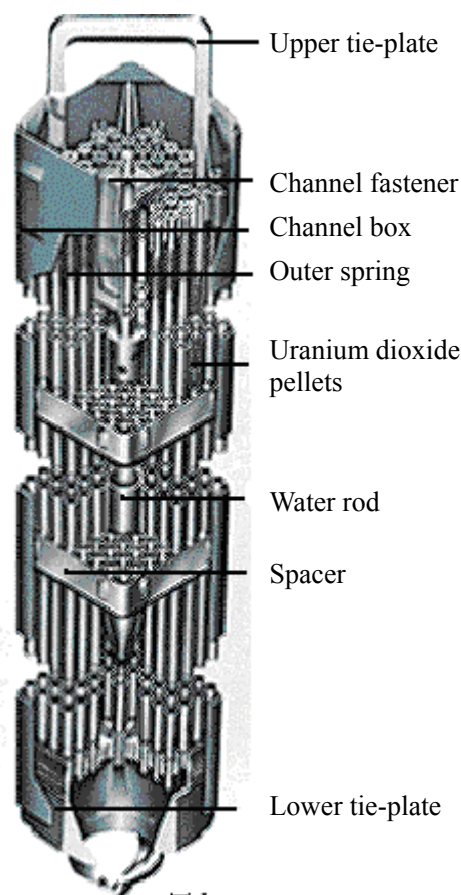
Utilizing their 30 years of experience in operating BWR reactors, a special care is made in selecting the right material. Cobalt has been eliminated from the design. The steel used in the primary system is made of nuclear grade material (low carbon alloys) which are resistant to intergranular stress corrosion cracking.

The ABWR reactor pressure vessel is 21 meters high and 7.1 meters in diameter.

The base metal of the reactor pressure vessel, which contains fuel assemblies, control rods and reactor internals, is made of low alloy steel and the inside surface of the vessel is lined with stainless steel to have a corrosion resistance.

Much of the vessel, including the 4 vessel rings from the core beltline to the bottom head, is made from single forging. The vessel has no nozzles greater than 2 inches in diameter anywhere below the top of the core because the external recirculation loops have been eliminated. Because of these two features, over 50% of the welds and all of the piping and pipe supports in the primary system have been eliminated and, along with it, the biggest source of occupational exposure in the BWR.

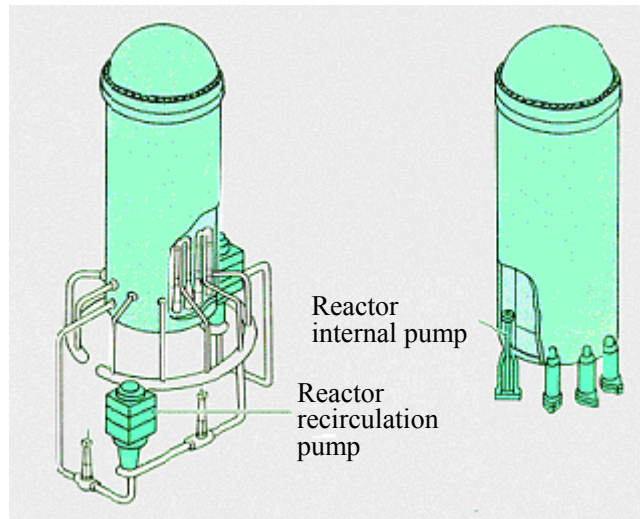
The reactor core comprises fuel assemblies as shown in Figure 10 and control rods. Each fuel rod in fuel assemblies contains sintered pellets of low-enriched uranium within a zirconium-lined cladding. They are brought together in fuel assemblies, 8x8 arrays of fuel rods held in place by upper and lower tie plates and spacers.



**Figure 10 ABWR Fuel**

## (2) External recirculation system eliminated

One of the unique features of the ABWR is its external recirculation system elimination. The external recirculation pumps and piping have been replaced by ten reactor internal pumps mounted to the bottom head. (Refer to Figure 11)



**Figure 11. Reactor Cooling Pump for BWR and ABWR**

Prior to the ABWR, all large commercial nuclear steam supply systems provided by GE from the BWR/3 through the BWR/6 designs used jet pump recirculation systems. These systems have two large recirculation pumps (each up to 9000 Hp) located outside of the reactor pressure vessel (RPV). Each pump takes a suction from the bottom of the downcomer region through a large diameter nozzle and discharges through multiple jet pumps inside of the RPV in the downcomer region. There is one nozzle per jet pump for the discharge back into the RPV and the external headers supplying these nozzles. Valves are required to isolate this piping in the event of a failure.

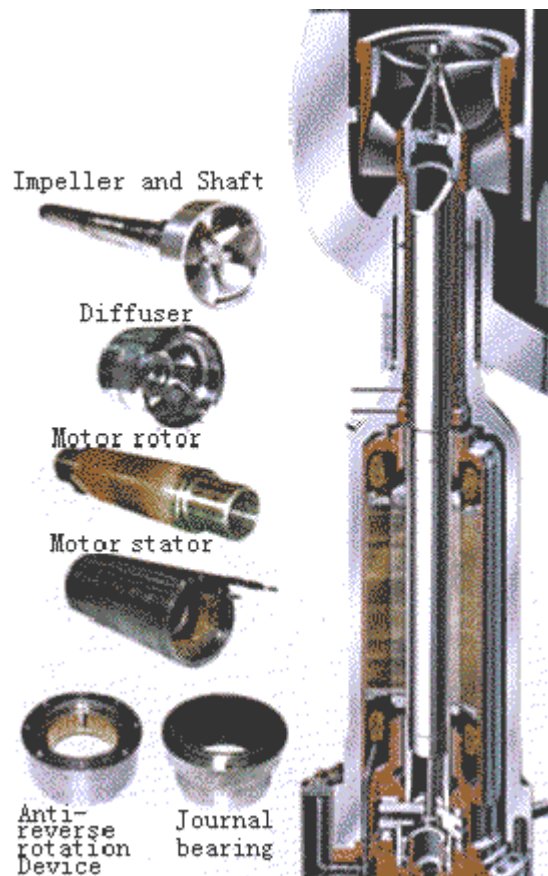
Consequently, reactor internal pumps eliminate all of the jet pumps (typically 10), all of the external piping, the isolation valves and the large diameter nozzles that penetrated the RPV.

## (3) Internal pump

Reactor internal pumps inside of the reactor pressure vessel (RPV) are a major improvement over previous BWR reactor plant designs (BWR/6 and prior). These pumps are powered by wet-rotor motors with the housings connected to the bottom of the RPV and eliminating large diameter external recirculation pipes that are possible leakage paths. The 10 internal pumps are located at the bottom of the downcomer region.

The first reactors to use reactor internal pumps were designed by ASEA-Atom (now Westinghouse Electric Company by way of mergers and buyouts, which is owned by Toshiba) and built in Sweden. These plants have operated very successfully for many years.

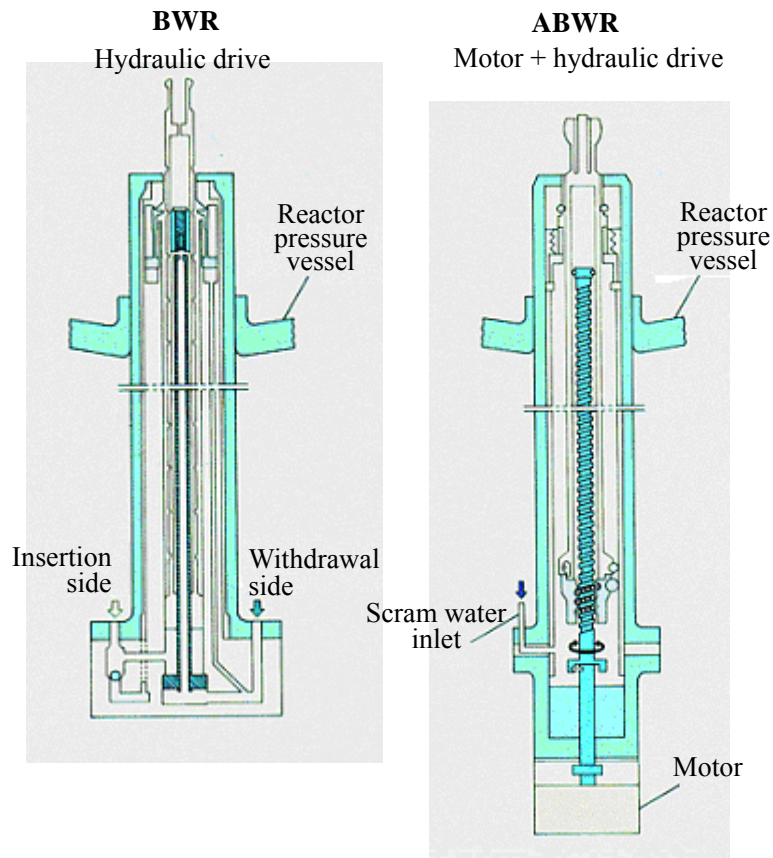
The internal pumps reduce the required pumping power for the same flow to about half that required with the jet pump system with external recirculation loops. Thus, in addition to the safety and cost improvements due to eliminating the piping, the overall plant thermal efficiency is increased. Eliminating the external recirculation piping also reduces occupational radiation exposure to personnel during maintenance.



**Figure 12. Reactor Internal Pump**

#### (4) Control rod and drive mechanism

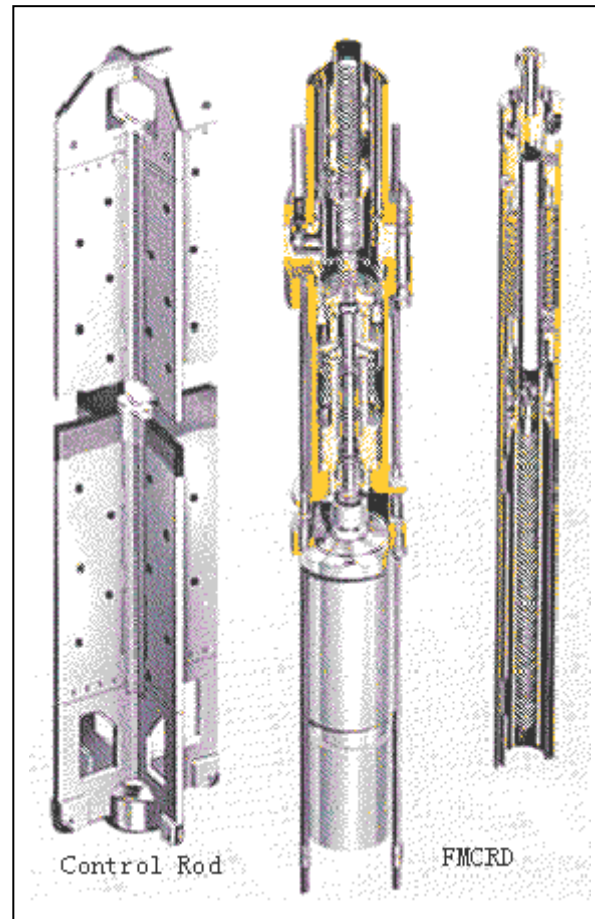
A operational feature in the ABWR design is electric fine motion control rod drives. BWRs use a hydraulic system to move the control rods which is driven by locking piston drive mechanism.



**Figure 13. Control Drive Mechanism for BWR and ABWR**

The materials in the control rods absorb neutrons and so restrain and control the reactor's nuclear fission chain reaction. The rods themselves have a cruciform cross section. They are inserted upwards, from the base of the RPV, into the rod spaces in fuel assemblies.

Fine motion control rod drives (FMCRD) are introduced in the ABWR. The control rods are scrammed hydraulically but can also be scrammed by the electric motor as a backup. The FMCRDs have continuous clean water purge to keep radiation to very low levels.



**Figure 14. Control Rod and Drive Mechanism**

### **(5) Safety - Simplified active safety systems**

ABWR has three completely independent and redundant divisions of safety systems. The systems are mechanically separated and have no cross connections as in earlier BWRs. They are electronically separated so that each division has access to redundant sources of ac power and, for added safety, its own dedicated emergency diesel generator. Divisions are physically separated. Each division is located in a different quadrant of the reactor building, separated by fire walls. A fire, flood or loss of power which disables one division has no effect on the capability of the other safety systems. Finally, each division contains both a high and low pressure system and each system has its own dedicated heat exchanger to control core cooling and remove decay heat. One of the high pressure systems, the reactor core isolation cooling (RCIC) system, is powered by reactor steam and provides the diverse protection needed should there be a station blackout.

The safety systems have the capability to keep the core covered at all times. Because of this capability and the generous thermal margins built into the fuel designs, the frequency of transients which will lead to a scram and therefore to plant shutdown have been greatly reduced (to less than one per year). In the event of a loss of coolant accident, plant response has been fully automated.

Any accident resulting in a loss of reactor coolant automatically sets off the emergency core cooling system (ECCS). Made up of multiple safety systems, each one functioning independently, ECCS also has its own diesel-driven standby generators that take over if external power is lost.

High pressure core flooder (HPCF) and reactor core isolation cooling (RCIC) systems: These systems inject water into the core to cool it and reduce reactor pressure.

Low pressure flooder (LPFL) system: Once pressure in the reactor vessel is reduced, this system injects water into the reactor vessel. The reactor core is then cooled safely.

Automatic-depressurization system: Should the high-pressure injection system fail, this system lowers the reactor vessel pressure to a level where the LPFL system can function.

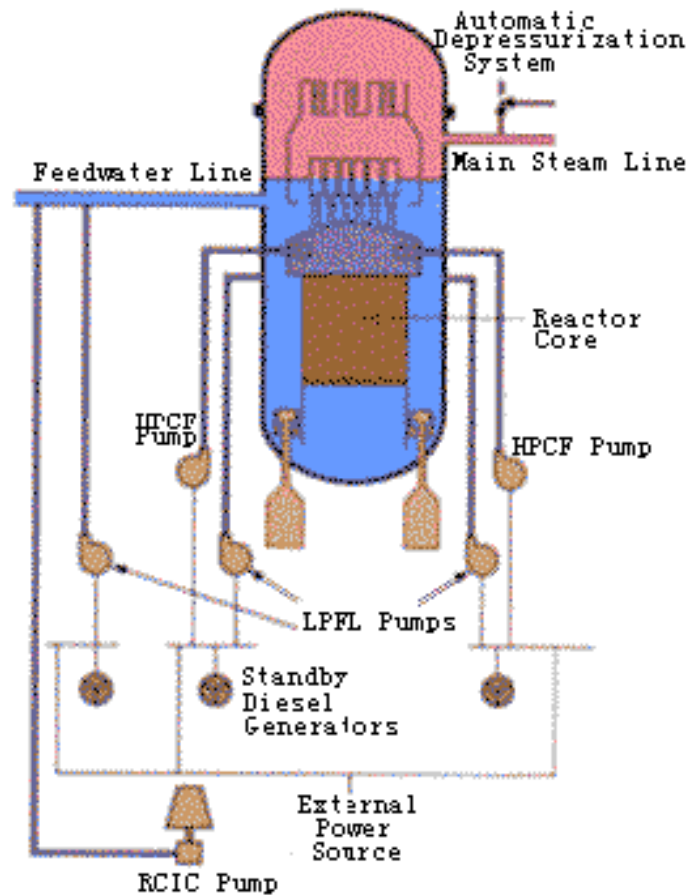
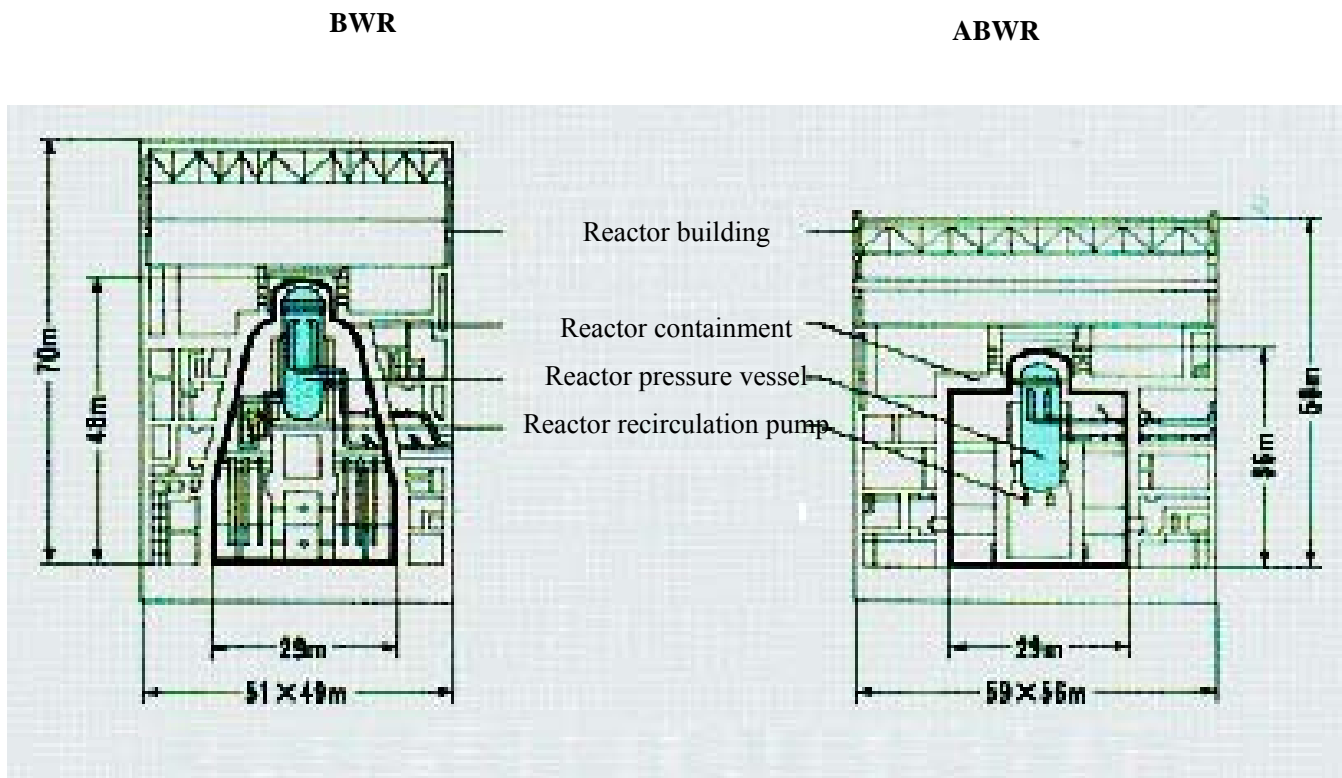


Figure 15. Emergency Core Cooling System (ECCS)

ECCS: Emergency Core Cooling System

HPCF: High Pressure Core Flooder (System), RCIC: Reactor Core Isolation Cooling (System), LPFL: Low Pressure Flooder (System), ADS: Auto-Depressurization System

The primary containment vessel encloses the reactor pressure vessel, other primary components and piping. In the highly unlikely event of an accident, this shielding prevents the release of radioactive substances. The ABWR uses a reinforced concrete containment vessel (RCCV). Its reinforced concrete outer shell is designed to resist pressure, while the internal steel liner ensures the RCCV is leak-proof. The compact cylindrical RCCV integrated into the reactor building enjoys the advantages of earthquake-resistant design and economic construction cost.



**Figure 16. Reactor Containment for BWR and ABWR**

### **(6) Digital control and instrumentation systems**

The control and instrumentation (C&I) systems use state of the art digital and fiber optic technologies. The ABWR has four separate divisions of safety system logic and control, including four separate, redundant multiplexing networks to provide absolute assurance of plant safety. Each system includes microprocessors to process incoming sensor information and to generate outgoing control signals, local and remote multiplexing units for data transmission, and a network of fiber optic cables. Multiplexing and fiber optics have reduced the amount of cabling in the plant.

### (7) Control room design

The entire plant can be controlled and supervised from the centered console and the large display panel in the main control room. The left side of console and large display panel is for the safety systems and the right side is for the balance of plant (turbine-generator, feedwater system etc.). The CRTs and flat panel displays on the centered console and the large display panel allow the operator to call up any system, its subsystems and components just by touching the screen. It is possible to operate an entire system in manual operation mode.



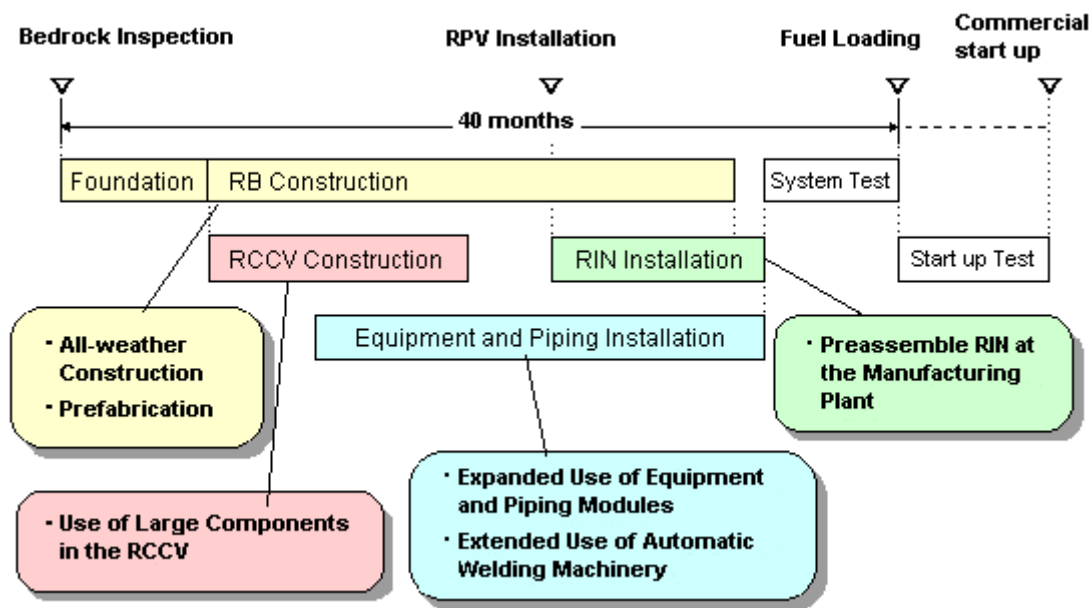
**Figure 17. Control Room Design**

### (8) Plant construction

The reactor and turbine building are arranged "in-line" and none of the major facilities are shared with the other units. The containment is a reinforced concrete containment vessel (RCCV) with a leak tight steel lining. The containment is surrounded by the reactor building, which doubles as a secondary containment. A negative pressure is maintained in the reactor building to direct any radioactive release from the containment to a gas treatment system. The reactor building and the containment are integrated to improve the seismic response of the building and the containment are integrated to improve the seismic response of the building without additional increase in the size and load bearing capability of the walls.

At construction of the plant large modules which are prefabricated in the factory are used and assembled to large structure on site. A 1000 ton-crawler crane will lift these modules and

place them vertically into the plant. Use of RCCV, modular construction and other construction techniques reduce construction times.



RCCV: Reinforced Concrete Containment Vessel  
 RPV: Reactor Pressure Vessel  
 RIN: Reactor Internals  
 RB: Reactor Building

**Figure 18. ABWR construction schedule (typical)**

Particular attention was paid to designing the plant for ease of maintenance. Monorails are available to remove equipment to a conveniently located service room via an equipment hatch.

Removal of the reactor internal pumps and FMCRDs for servicing has been automated. Handling devices, which in the case of the FMCRD is operated remotely from outside the containment, engage and remove the equipment. The pump or driver is laid on a transport device and removed through the equipment hatch. Just outside the hatch are dedicated service rooms, one for the RIPs and another for the FMCRDs, where the equipment can be decontaminated and serviced in a shielded environment. The entire operation is done efficiently and with virtually no radiation exposure to the personnel.

## Chapter 6. Economic Simplified Boiling Water Reactor (ESBWR)

### 6.1 ESBWR and Natural Recirculation

The Economic Simplified Boiling Water Reactor (ESBWR) is a passively safe generation III+ reactor which builds on the success of the ABWR. Both are designs by General Electric, and

are based on their BWR design. The plant data are shown in Table 4.

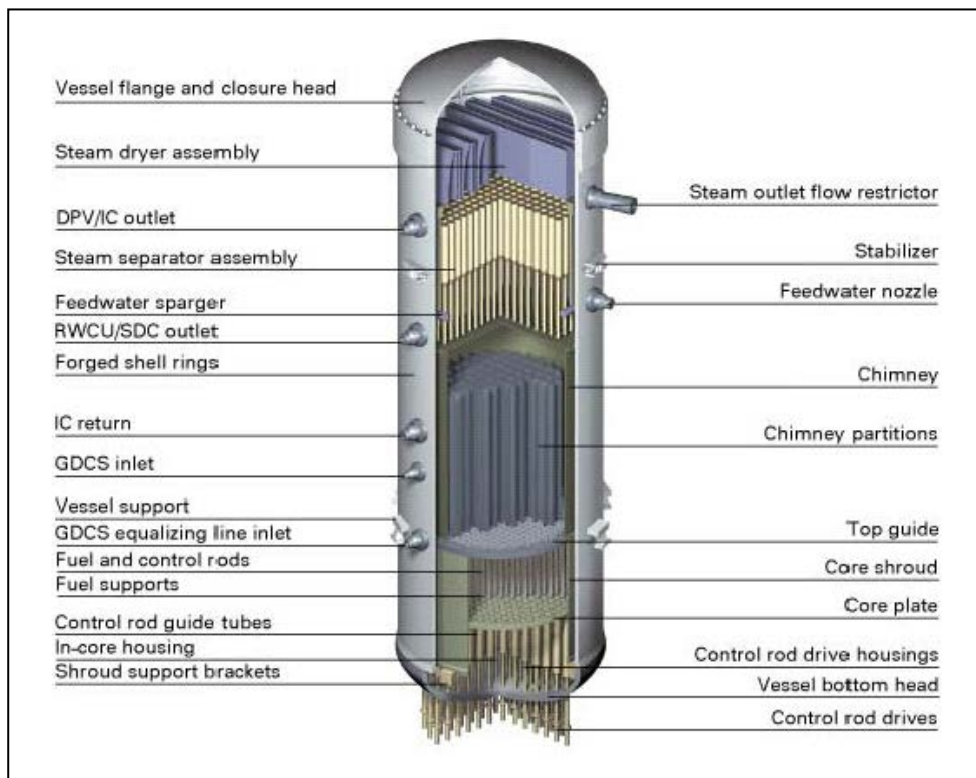
**Table 4. ESBWR Technology Fact Sheet**

|  |                                |
|--|--------------------------------|
| Plant Life (years)   | 60                             |
| Thermal Power  | 4,500 MW                       |
| Electrical Power   | 1,560 MW                       |
| Plant Efficiency   | 34.7 %                         |
| Reactor Type   | Boiling Water Reactor          |
| Core   |                                |
| Fuel Type  | Enriched UO <sub>2</sub>       |
| Fuel Enrichment  | 4.2%                           |
| No. of Fuel Bundles  | 1,132                          |
| Coolant  | Light water                    |
| Moderator  | Light water                    |
| Operating Cycle Length   | 12-24 months                   |
| Outage Duration  | ~14 days                       |
| Percent fuel replaced at refueling   | See footnote 4                 |
| Average fuel burnup at discharge   | ~50,000 MWd/MT                 |
| Number of Steam Lines  | 4                              |
| Number of Feedwater Trains   | 2                              |
| Containment Parameters   |                                |
| Design Temperature   | 340°F                          |
| Design Pressure  | 45 psig                        |
| Reactor Parameters   |                                |
| Design Temperature   | 575°F                          |
| Operating Temperature  | 550°F                          |
| Design Pressure  | 1,250 psig                     |
| Nominal Operating Pressure   | 1,040 psia                     |
| Feedwater & Turbine Parameters   |                                |
| Turbine Inlet/Outlet Temperature   | 543/93°F                       |
| Turbine Inlet/Outlet Pressure  | 985/0.8 psia                   |
| Feedwater Temperature  | 420°F                          |
| Feedwater Pressure   | 1,050 psia                     |
| Feedwater Flow   | 4.55 x 10 <sup>4</sup> gpm     |
| Steam mass flow rate   | 19.31 x 10 <sup>6</sup> lbs/hr |
| Yearly Waste Generated   |                                |
| High Level (spent fuel)  | 50 metric tons                 |
| Intermediate Level (spent resins, filters, etc.) and Low Level (compactable/non-compactable) Waste | 1,765 cubic                    |

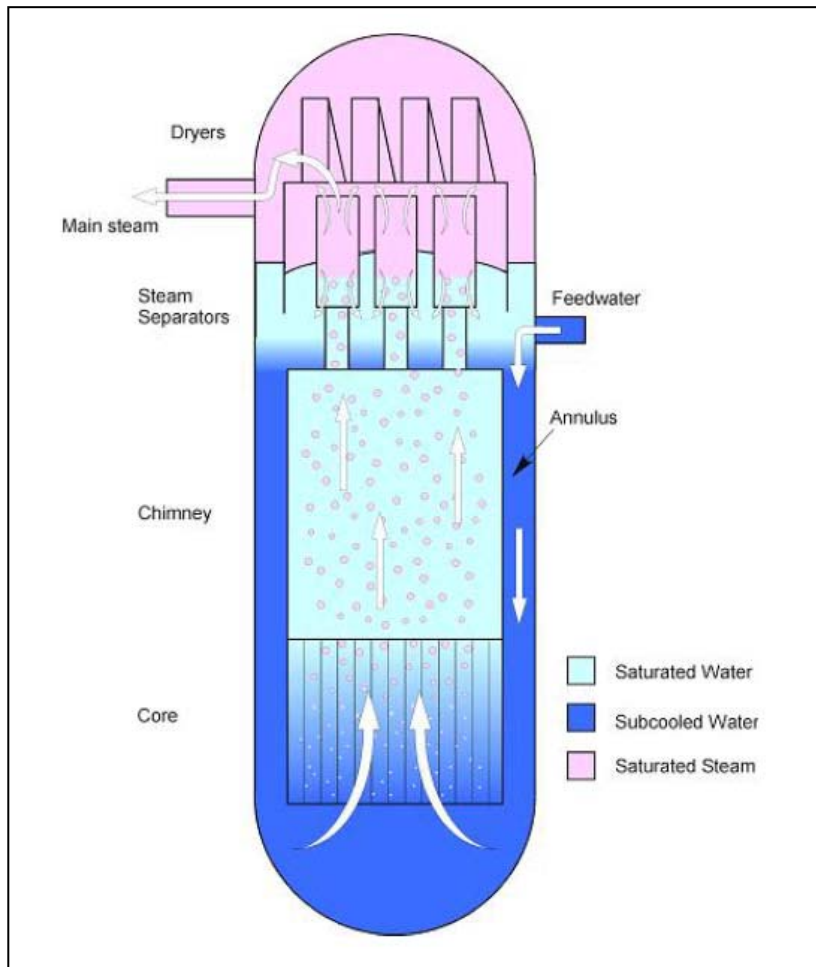
The ESBWR uses natural circulation with no recirculation pumps or their associated piping.

Through design simplification, natural circulation in GE's ESBWR will decrease Operations and Maintenance (O&M) costs, reducing the overall cost of plant ownership. Natural circulation provides simplification over previous Boiling Water Reactor (BWR) and all Pressurized Water Reactor (PWR) designs that rely on forced circulation. This improvement is accomplished by the removal of recirculation pumps and associated motors, piping, valves, heat exchangers, controls, and electrical support systems that exist with forced circulation. Natural circulation in the ESBWR also eliminates the risk of flow disturbances resulting from recirculation pump anomalies.

The ESBWR and internals is shown in Figure 19. and the natural recirculation of ESBWR is shown in Figure 20.



**Figure 19. ESBWR and Internals**



**Figure 20. ESBWR Natural Recirculation**

Natural circulation is consistent with the key objectives of the ESBWR program: a passive safety design with simplification achieved by evolutionary enhancements. Most of the components in the ESBWR design are standard to BWRs and have been operating in the commercial nuclear energy fleet for years. The main differences between natural and forced circulation are the additions of:

- A partitioned chimney above the reactor core to stabilize and direct the steam and water flow above the core.
- A correspondingly taller, open down-comer annulus that reduces flow resistance and provides additional driving head, pushing the water to the bottom of the core.

Natural circulation is a proven technology. Valuable operating experience was gained from previously employed natural circulation BWR designs. Examples of plants using only natural circulation include the Humboldt Bay plant in California and the Dodewaard plant in the Netherlands, which operated for 13 and 30 years respectively.

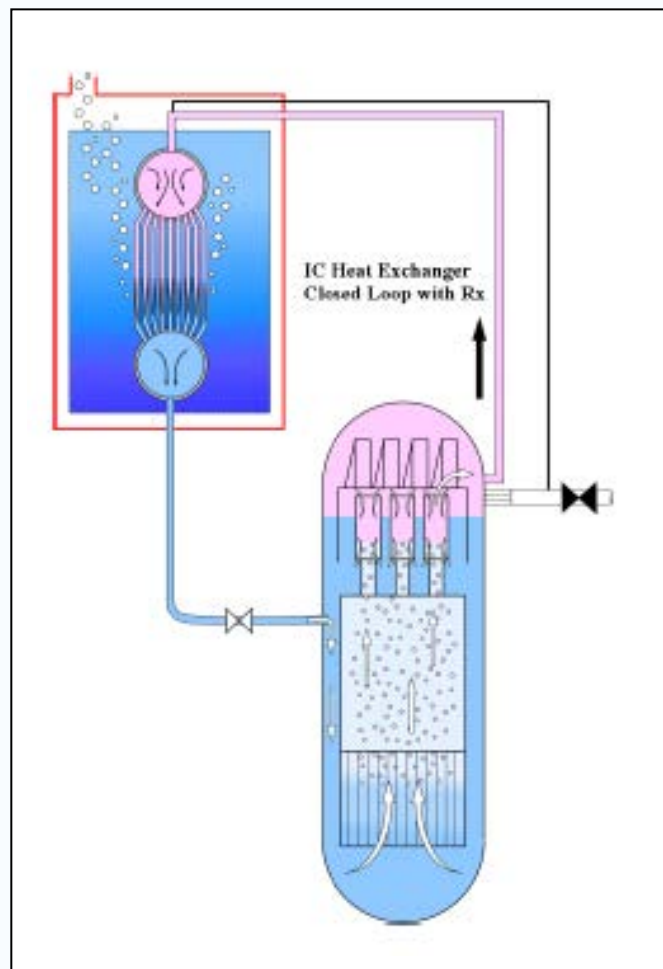
Today, large (>1000MW) BWRs can generate about fifty percent of rated power in natural

circulation mode. The operating conditions in this mode—power, flow, stability, steam quality, void fraction, void coefficient, power density, and power distribution—are predicted by GE calculation models that were calibrated against operating plant data from LaSalle, Leibstadt, Forsmark, Confrontes, Nine Mile Point 2, and Peach Bottom 2. The ESBWR utilizes proven natural circulation technology to operate a reactor with the size and performance characteristics customers need today at one hundred percent of rated power.

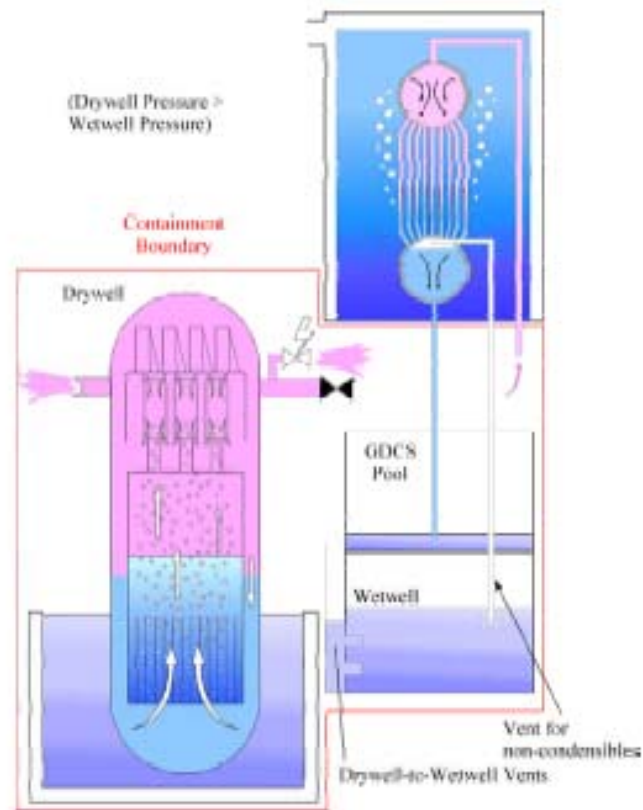
## 6.2 ESBWR Passive Safety Design

The passively safe characteristics are mainly based on isolation condensers, which are heat exchangers that take steam from the vessel (Isolation Condensers, IC) or the containment (Passive Containment Cooling System, PCCS), condense the steam, transfer the heat to a water pool, and introduce the water into the vessel again.

Those systems are illustrated in Figure 21 and 22.

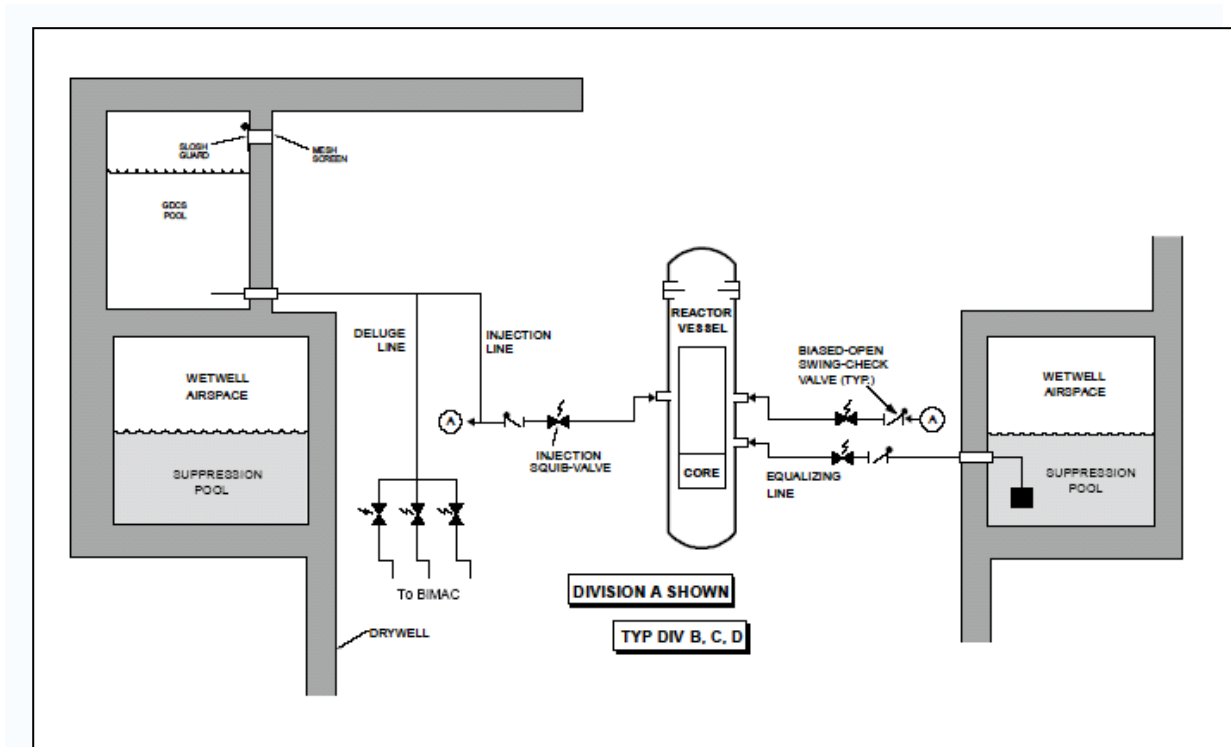


**Figure 21. Isolation Condenser System**



**Figure 22. Passive Containment Cooling System**

This is also based on the gravity driven cooling system (GDCS) shown in Figure 23, which are pools above the vessel that when very low water level is detected in the reactor, the depressurization system opens several very large valves to reduce vessel pressure and finally to allow these GDCS pools to reflood the vessel.



**Figure 23. Gravity-Driven Cooling System**

The core is shorter than conventional BWR plants because of the smaller core flow (caused by the natural circulation). There are 1132 bundles and the thermal power is 4500 MWth (1550 MWe).

Below the vessel, there is a piping structure which allows for cooling of the core during a very severe accident. These pipes divide the molten core and cool it with water flowing through the piping.

The probability of radioactivity release to the atmosphere is several orders of magnitude lower than conventional nuclear power plants, and the building cost is 60-70% of other light water reactors.

The energy production cost is lower than other plants due to:

1. Lower initial capital cost
2. Lower operational and maintenance cost

General Electric has recalculated maximum core damage frequencies per year per plant for its nuclear power plant designs:

BWR/4 --  $1 \times 10^{-5}$  (a typical plant)

BWR/6 --  $1 \times 10^{-6}$  (a typical plant)

ABWR --  $2 \times 10^{-7}$  (now operating in Japan)

ESBWR --  $3 \times 10^{-8}$  (submitted for Final Design Approval by NRC)

The ESBWR's maximum core damage frequency is significantly lower than that of the AP1000 or the European Pressurized Reactor.

### **Chapter 7. Current status**

As of December 2006, four ABWRs were in operation in Japan: Kashiwazaki-Kariwa units 6 and 7, which opened in 1996 and 1997, Hamaoka unit 5, opened 2004 having started construction in 2000, and Shika 2 commenced commercial operations on March 15, 2006. Another two, identical to the Kashiwazaki-Kariwa reactors, were nearing completion at Lungmen in Taiwan, and one more (Shimane 3) had just commenced construction in Japan, with major siteworks to start in 2008 and completion in 2011. Plans for at least six other ABWRs in Japan have been postponed, cancelled, or converted to other reactor types, but three of these (Higashidori 1 and 2 and Ohma) were still listed as *on order* by the utilities, with completion dates of 2012 or later.

Several ABWRs are proposed for construction in the United States under the Nuclear Power 2010 Program. However these proposals face fierce competition from more recent designs such as the ESBWR (Economic Simplified BWR, a generation III+ reactor also from GE) and the AP1000 (Advanced, Passive, 1000MWe, from Westinghouse). These designs take passive safety features even further than the ABWR does, as do more revolutionary designs such as the pebble bed modular reactor.

On June 19, 2006 NRG Energy filed a Letter Of Intent with the Nuclear Regulatory Commission to build two 1358-MWe ABWRs at the South Texas Project site.

New Reactor Licensing Applications in US including ABWR and ESBWR from 2005 to 2010 and beyond are shown in the Figure 24.

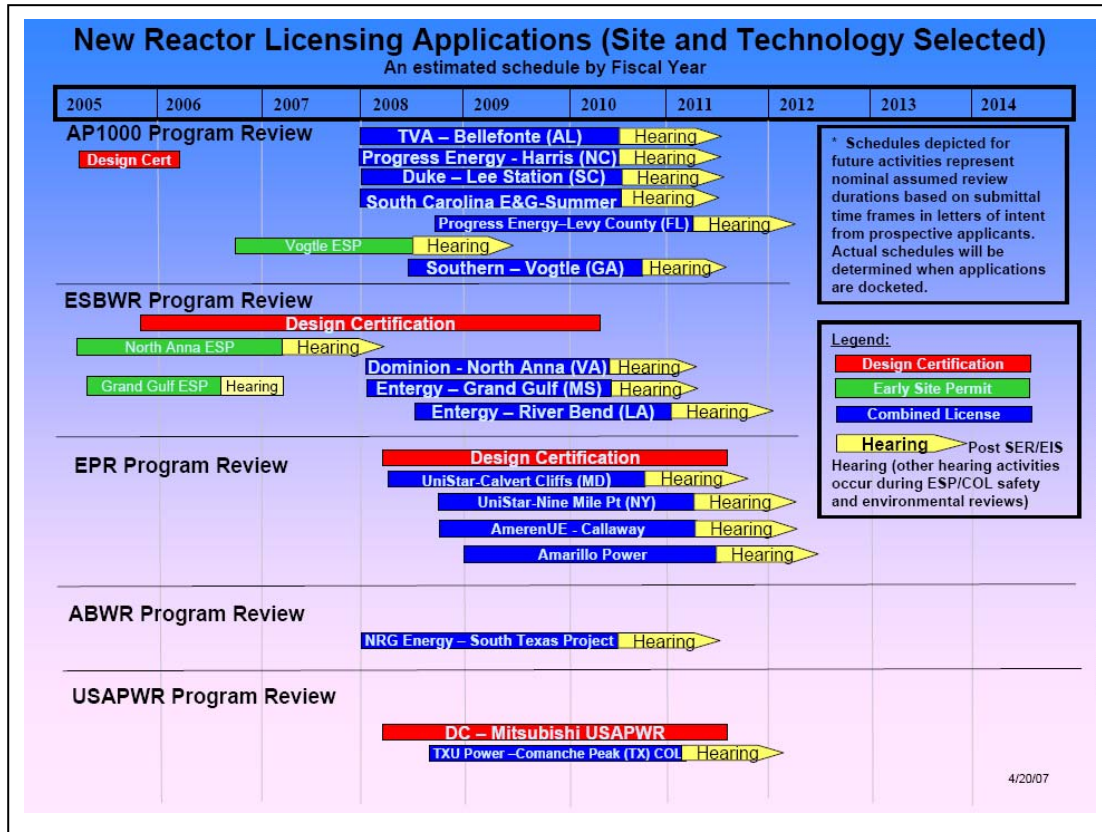


Figure 24. New Reactor Licensing Applications in US

## References

NRC HP: <http://www.nrc.gov/>

Wikipedia: <http://en.wikipedia.org/>

ATOMICA: <http://www.rist.or.jp/atomica/>

Handbook for Thermal and Nuclear Power Engineers, English Edition of the 6<sup>th</sup> Edition, 2002, Thermal and Nuclear Power Engineering Society of Japan (TENPES)

Nuclear Power Generation Guide, 1999 Edition, Edited by Nuclear Power Division, Public Utilities Department, Agency for Natural Resources and Energy, Ministry of International Trade and Industry, Published by Denryoku Shinnpou Sha (October 1999)

Outline of a LWR Power Station (Revised edition), Nuclear Safety Research Association (1992 October)

Outline of Safety Design (Case of BWR), Long-term Training Course on Safety Regulation and Safety Analysis / Inspection, NUPEC, (2002)

Toshiba HP: <http://www.toshiba.co.jp/>

GE HP: <http://www.ge.com/>

GE HP, ESBWR Overview, J. Alan Beard), September 15, 2006

Nuclear Renaissance, a Former Regulator's Perspective Regarding the NRC Role and Activities, Ashok Thadani

**Revision control of the textbook**

| <b>Status</b> | <b>Date Updated</b> | <b>Comment</b>   |
|---------------|---------------------|------------------|
| R0-r0         | March 15, 2011      | Initial Issuance |
|               |                     |                  |
|               |                     |                  |